



PARTS - BOARD SETS

Check out our board sets for 2008 - now with new parts, new apps, and more!

Also available - our new Tool Board Set (Part No. 87910) on page 83 - Our most popular tools all on one easy to store and inventory board.

88210

TRUCK SLEEVE BOARD

Containing our most popular sleeves, this board set gives you excellent application coverage, including the new F150, F250 and F350 trucks while keeping inventory in check. **Shipped with our high-strength polymer display board, hooks and labels.**

BOARD INCLUDES ONE EACH OF THE FOLLOWING:

- 23102, 23104, 23106, 23108, 23109, 23112** Change camber & caster on many popular Ford 4WD trucks including older F250, F350 and full sized Broncos
- 23132, 23134, 23136, 23138, 23139** Camber/caster sleeves for Ford and Dodge trucks including Ford 4WD F350 Crew Cabs and Dodge 4WD BR2500 and 2WD & 4WD BR3500 Vans .
- 23182, 23184, 23186, 23188, 23190, 23199** Adjusts camber and caster on Ford 2WD F150, F250 (L/D), F350, Bronco II, Explorer and Ranger, along with Ford 4WD Bronco II, Explorers and Rangers.
- 23212, 23222, 23224, 23226, 23228, 23229** Our new camber/caster sleeves for 2005 & Up F250 and F350 4WD Ford Super Duty's.
- 24120, 24130, 24180, 24220, 74400, 74500** Adjustable truck sleeves add versatility to this set, along with our special wrenches that make installation easier.



PARTS BOARD SETS

88260

PASSENGER CAR ASSORTMENT BOARD

This Board Set includes our most popular shims, cam kits and adjustable strut plates. This is a "must have" for any shop performing 4 wheel alignments on passenger cars. **Shipped with our high-strength polymer display board.**

BOARD INCLUDES THE FOLLOWING:

- 75200, 75400, 75800** **EZ Shims™** - a patented full contact, dual angle shim set that corrects toe and camber with one shim. These shims cover many rear shimable FWD vehicles on the road today. **#75200, 75400 and #75800 - 2 of each shim included**
- 75915** **EZ Shim™ Cutter** - A necessary tool for properly cutting EZ Shims™. **1 included**
- 75970** **EZ Shim™ Caliper Spacer Set** - Aligns caliper to rotor after installing our EZ Shims™ on some FWD cars with hub mounted rear brakes. **1 set included**
- 10408** **Hub Replacement Bolt Set** - to be used when installing rear shims. **1 set included**
- 81250, 81260, 81270, 81280, 81290** **EZ Cams XR™** - Camber kits for domestic and imported vehicles with two bolt non-slotted struts. Sizes include 12mm, 14mm, 15mm, 16mm and 17mm. **#81250 and #81260 - 2 kits included, #81270, 81280 and 81290 - 1 kit included**
- 71720, 71721, 71722, 71723, 71730, 71731, 71733** **Chrysler and Dodge Mini Van Rear** Camber and Toe Shims. The shim you need to align this very popular platform. **1 of each shim included**
- 81310** **Ford Focus Rear** Camber Kit. **1 kit included**
- 81320** **Ford Focus Front** Camber/Caster adjustable upper strut plate. **1 kit included**



88270

LIGHT TRUCK/SUV BOARD

This great new board set includes the most popular parts for aligning today's trucks and SUVs. Don't be caught without the part that you need. **Shipped with our polymer display board.**

BOARD INCLUDES ONE (1) EACH OF THE FOLLOWING:

- 23755** **Dodge 4x4** - 2002 & Up Camber/Caster kit for 4 Wheel Drive BR1500s.
- 23765** **Dodge 4x2** - 2002 & Up Camber/Caster kit for 2 Wheel Drive BR1500s.
- 86140** **Ford Explorer Front Kit** - For 2002 & Up Explorers and Mountaineers.
- 86240** **Ford F150 Camber/Caster Kit** - Front kit for the 2004 & Up F150s
- 86640** **Expedition Front Kit** - For 2002 & Up Expeditions & 2003 & Up Navigators
- 87310** **Explorer Front Camber/Caster Kit** - Cams for 1995 - 01 Explorers and Mountaineers along with 1998 & Up Rangers.
- 87385** **Ford F150 Front Camber** - Cam bolt assemblies for 1997 - 03 F150s and F250(LD)s.
- 87400** **GM 2WD & 4WD Camber/Caster Kit** - For 1988 - 99 C & K 1500, 2500 and 3500s.
- 86350** **GM 1/2 & 3/4 Ton Camber Bushings** - For 2002 & Up C & K 1500s, Suburbans and more.
- 86320** **GM 1/2 & 3/4 Ton Cam Lock Plates** - For 2002 & Up C & K 1500, 2500 and 3500s.
- 86325** **GM 1/2 & 3/4 Ton Alignment Pins** - For 2002 & Up C & K 1500, 2500 and 3500s.
- 86330** **GM 1/2 & 3/4 Ton Camber Bushings** - For 2002 & Up C & K 2500 and 3500s.
- 87520** **Nissan Camber/Caster Kit** - For 2004 & Up Titan, and 2005 & Up Pathfinder, Xterra and more.



1-800-525-6505

Call for your nearest distributor, product info or technical assistance in the USA and Canada

www.specprod.com
www.spcalignment.com

BUILD A TOTAL WHEEL ALIGNMENT CUSTOM INVENTORY CONTROL BOARD ANY WAY YOU LIKE IT...

Our complete line of alignment parts may now be displayed in any grouping you would like on a custom inventory control board. The requirements consist of purchasing a minimum of 12 part numbers (excluding SLA shims) of your choice. You select the product, we will package the board, hooks and labels for you to customize your board set. Just copy the form below and mail or fax it to your local distributor, or to Specialty Products for us to forward to your closest distributor. **The board, hooks and labels are *no charge* when 12 different part numbers are purchased.**



DATE _____ PHONE _____ YOUR P.O. NUMBER _____

Bill To:

Ship To:

CUSTOM INVENTORY CONTROL BOARD NO. 88120 - LAYOUT FORM.

Write our part number in the boxes below and the quantity you would like. Each space can hold up to 3 items. Order up to 20 part numbers OR up to 30 truck sleeve part numbers.

Part No. _____ Qty. _____ <i>(Up to three)</i>	Part No. _____ Qty. _____ <i>(Up to three)</i>	Part No. _____ Qty. _____ <i>(Up to three)</i>	Part No. _____ Qty. _____ <i>(Up to three)</i>	Additional Part No. <i>(Truck Sleeves Only)</i> _____ Qty. _____ <i>(Up to three)</i>
Part No. _____ Qty. _____ <i>(Up to three)</i>	Part No. _____ Qty. _____ <i>(Up to three)</i>	Part No. _____ Qty. _____ <i>(Up to three)</i>	Part No. _____ Qty. _____ <i>(Up to three)</i>	Additional Part No. <i>(Truck Sleeves Only)</i> _____ Qty. _____ <i>(Up to three)</i>
Part No. _____ Qty. _____ <i>(Up to three)</i>	Part No. _____ Qty. _____ <i>(Up to three)</i>	Part No. _____ Qty. _____ <i>(Up to three)</i>	Part No. _____ Qty. _____ <i>(Up to three)</i>	Additional Part No. <i>(Truck Sleeves Only)</i> _____ Qty. _____ <i>(Up to three)</i>
Part No. _____ Qty. _____ <i>(Up to three)</i>	Part No. _____ Qty. _____ <i>(Up to three)</i>	Part No. _____ Qty. _____ <i>(Up to three)</i>	Part No. _____ Qty. _____ <i>(Up to three)</i>	Additional Part No. <i>(Truck Sleeves Only)</i> _____ Qty. _____ <i>(Up to three)</i>
Part No. _____ Qty. _____ <i>(Up to three)</i>	Part No. _____ Qty. _____ <i>(Up to three)</i>	Part No. _____ Qty. _____ <i>(Up to three)</i>	Part No. _____ Qty. _____ <i>(Up to three)</i>	Additional Part No. <i>(Truck Sleeves Only)</i> _____ Qty. _____ <i>(Up to three)</i>
Additional Part No. <i>(Truck Sleeves Only)</i> _____ Qty. _____ <i>(Up to three)</i>	Additional Part No. <i>(Truck Sleeves Only)</i> _____ Qty. _____ <i>(Up to three)</i>	Additional Part No. <i>(Truck Sleeves Only)</i> _____ Qty. _____ <i>(Up to three)</i>	Additional Part No. <i>(Truck Sleeves Only)</i> _____ Qty. _____ <i>(Up to three)</i>	Additional Part No. <i>(Truck Sleeves Only)</i> _____ Qty. _____ <i>(Up to three)</i>

Board Dimensions: 23-1/2" x 32". May be hung horizontally or vertically.

IMPORTANT: YOUR PHONE NUMBER, IN CASE WE HAVE QUESTIONS ABOUT YOUR ORDER:

HOW TO USE THIS ORDER FORM:

- COPY THIS FORM ON YOUR COPY MACHINE.**
- Choose at least 12 parts from any* listed in our current catalog and get the board, hooks & labels **FREE!** Remember - They need to fit on our Custom Control Board.
- Write the part number and quantity needed in the spaces indicated on the board layout.
- Assign a purchase order number to this order, fill in your company name and address(es), then mail or fax it to your distributor or fax to 1-303-772-1918 and Specialty Products will forward it to your closest distributor.
- Product indicated will be shipped with each Custom Inventory Control Board unless requested differently by customer.

* **Some exclusions do occur, please call for more information.**



PARTS - SHIMS

75200 75400 75800

EZ Shim™ FULL CONTACT DUAL ANGLE

A patented Full Contact Dual Angle shim consisting of only three part numbers that corrects Toe and Camber with one shim.

These two-piece shims are available individually or in MasterPaks of 25. Instruction sheets are included in each shim package. Various combinations of the shims and shim accessories are included on 88700 Dual Angle Shim Board, 88715 EZ Shim™ and our Passenger Car Assortment Board (88260, pg. 40).

CAUTION: Check for caliper to rotor clearance when installing this part on vehicles equipped with rear disc brakes. Some vehicles may require the use of longer bolts. Recommend use of 10408 bolts and 75970 spacers as required (see below).

U.S. Patents 5,622,378 & 4,836,597 • EPO 0695255

75915 - EZ Shim Cutter (below)

Rear Adjustment range:
Camber -1.50° to +1.50°
Toe -1.50° to +1.50°

Installation time: .5 hr/side

Required: 1 shim per wheel

APPLICATIONS See application charts, pages 7-37 for vehicle models and years.

75200 (BLUE)

Audi, Chevrolet, Chrysler, Dodge, Eagle, Ford, Geo, Isuzu, Plymouth, VW

75400 (GREY)

Acura, Audi, Buick, Cadillac, Chevrolet, Chrysler, Dodge, Ford, Mercury, Nissan, Olds, Plymouth, Pontiac, Saturn

75800 (RED)

Buick, Cadillac, Chevrolet, Geo, Olds, Pontiac, Toyota, VW



88700



EZ SHIM™ BOARD SET

Full coverage of all (3) EZ Shims, plus the tools needed to complete the installation. Hanging board allows for better inventory control.

BOARD INCLUDES:

- 88120** 23-1/2"x 32" Board w/ hooks
- 75200** EZ Shims - Blue (6)
- 75400** EZ Shims - Grey (6)
- 75800** EZ Shims - Red (6)
- 75910** EZ Shim™ Dial Chart (1)
- 75915** EZ Shim™ Cutter (1)
- 75920** EZ Shim™ Marker (1)



75910
EZ Shim™ dial Chart lists changes in decimal degrees only.

75910 DIAL CHART

Makes using the EZ Shim a snap. Just dial in the desired change needed for both camber and toe.



75915

75915 CUTTER

This cutter is a necessary tool for cutting the EZ Shim™ Its thin cutting blades minimize shim breakage.



75920

75920 MARKER

This will mark the areas to be removed. Marks will not rub off, and are easy to see.



75970

75970 SPACER SET (8)

This set (4 different sizes - 2 of each) aligns caliper to rotor after installation of a camber shim. Specifically designed to be used with the EZ Shim when correcting some FWD cars with hub mounted rear disc brakes. Can also be used with the 71000 Series Shims (pg 44).



EZ SHIM™ ONLINE

Get up to date templates and applications online with our new EZ Shim Online program. Easy to follow shim selection for the EZ Shim with instructions and videos to help you install your shim. Go to www.spcalignment.com/ezshim

10408



GM REAR HUB REPLACEMENT BOLT SET

Contains 8 M10 x 1.5 x 40mm allen head rear hub bolts to be used with the rear shims when needed.

1-800-525-6505

Call for your nearest distributor, product info or technical assistance
In the USA and Canada

www.specprod.com
www.spcalignment.com

Rear Adjustment range:
Camber & Toe -1.00° to $+1.00^{\circ}$
Installation time: .5 hr/side
Required: 1 shim per wheel/
per angle changed

APPLICATIONS

Toyota: 1998 & Up Sienna

CAMBER/TOE	
Part No.	Change
71020	.06°
71021	.13°
71022	.25°
71023	.38°
71024	.50°
71025	.75°

TOYOTA SIENNA REAR SHIMS

These new full contact rear shims will correct camber and/or toe. Combination adjustments, or changes up to 1.0° may be achieved by using 2 shims on each wheel.



71020 SERIES

NOTE: Do NOT adjust Camber or Toe over 1.0°

71000 SHIM SET - Includes 12 shims/2 of each size.

Rear Adjustment range:
Camber $\pm.50^{\circ}$ to $\pm 1.00^{\circ}$
Toe $\pm.13^{\circ}$ to $\pm.50^{\circ}$
Installation time: .5 hr/side
Required: 1 shim per wheel/
per angle changed

APPLICATIONS

Audi:

2000 - 06 TT

Volkswagen:

1999 & Up Beetle

1999 - 06 Golf (Except R32)

1999 - 06 GTi

1999 - 05 Jetta



87530 - VW Shim Wrench, pg. 96

VOLKSWAGEN REAR SHIMS

With these shims you can correct both rear camber and rear toe on newer Volkswagens and Audis. By combining the shims (two may be used on each wheel) you can get up to ± 1.0 camber change and up to $+ .50^{\circ}$ toe change. Our wrench (**87530**) is a must when installing these shims. It allows you to remove the brake tone ring, bearing, seal and hub assembly as one unit.

71500 SHIM SET - Includes 16 shims/2 of each size and 87530 wrench.

TOE		CAMBER	
Part No.	Change	Part No.	Change
71520	$\pm.13^{\circ}$	71530	$+ .50^{\circ}$
71521	$\pm.25^{\circ}$	71531	$+ 1.00^{\circ}$
71522	$\pm.38^{\circ}$	71532	$- .50^{\circ}$
71523	$\pm.50^{\circ}$	71533	$- 1.00^{\circ}$

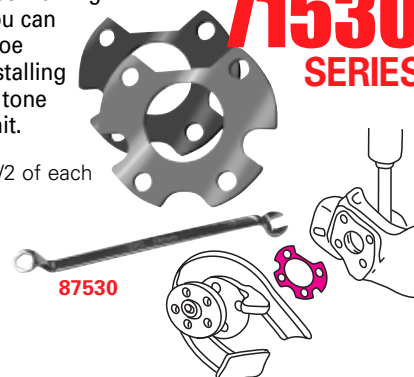

NOTE: When installing these shims it is recommended that you use our VW Shim Wrench (P/N 87530 pg. 96) to assist in removing the rear hub. CAUTION: Check brake & rotor clearance for binding. 75970 spacers maybe required.

Rear Adjustment range:
Camber -1.00° to $+1.00^{\circ}$
Toe $\pm.10^{\circ}$ to $\pm.80^{\circ}$
Installation time: .5 hr/side
Required: 1 shim per wheel/
per angle changed

APPLICATIONS

Chrysler: 1996 & Up Town & Country, 1990 - 95 Town & Country AWD w/o ABS

Dodge: 1996 & Up Caravan, 1990 - 95 Caravan AWD w/o ABS

Plymouth: 1996 & Up Voyager, 1990 - 95 Voyager AWD w/o ABS

CHRYSLER MINI-VAN SHIMS

For camber and toe change, use our Mini-Van Shims that allow for quick and easy changes in increments of: toe $.10^{\circ}$ and camber $.25^{\circ}$.

71700 SHIM SET - Includes 20 shims/2 of each size.

TOE		CAMBER	
Part No.	Degree of Change	Part No.	Degree of Change
71720	$\pm.10^{\circ}$ [.05" (1/16")]	71723	$\pm.40^{\circ}$ [.20" (3/16")]
71721	$\pm.20^{\circ}$ [.10" (1/8")]	71724	$\pm.50^{\circ}$ [.25" (1/4")]
71722	$\pm.30^{\circ}$ [.15" (5/32")]	71725	$\pm.80^{\circ}$ [.40" (3/8")]
		71730	$\pm.25^{\circ}$ (1/4°)
		71731	$\pm.50^{\circ}$ (1/2°)
		71732	$\pm.75^{\circ}$ (3/4°)
		71733	$\pm 1.00^{\circ}$ (1°)

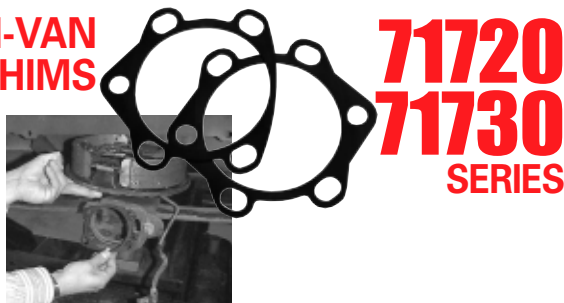

Rear Adjustment range:
Camber $+ .25^{\circ}$ to $+ .75^{\circ}$
Installation time: .3 hr/side
Required: 1 kit per axle

APPLICATIONS

Chrysler: 1995 - 00 Sebring/JL, 2001 & Up Sebring 2Dr, Coupe

Dodge: 1995 - 00 Avenger

Eagle: 1995 - 99 Talon 2/4WD

Mitsubishi: 1995 - 05 Eclipse 2/4WD, 1997 - 04 Diamante, 1994 - 03 Galant

CHRYSLER/MITSUBISHI REAR SHIM PACK

For positive camber change use our **73400** Rear Shims (6 per pack) that allow for quick and easy camber changes in increments of $.25^{\circ}$ up to $.75^{\circ}$. Each shim changes camber by $.25^{\circ}$, the entire pack equals $.75^{\circ}$ change if all shims are used.

73415 BOLT SET - Set of 4 bolts.



73400 SHIM PACK

NOTE: Changes in camber greater than $.75^{\circ}$ require an additional shim kit and the installation of longer bolts. Use Specialty Part 73415.

Rear Wheel Shims NYLON SHIM INSTALLATION

For shim installation, determine the amount of change needed. Remove rear wheel and tire, brake drum/ rotor, and rear hub. Select correct shim for amount of change desired and install. Reassemble, torque bolts and continue alignment.

CAUTION: Check for caliper to rotor clearance when installing on vehicles equipped with rear disc brakes. Some vehicles may require longer bolts. Use 10408 bolts and 75970 spacers as required (pg 42).

71100 FULL CONTACT NYLON SHIMS

Adjust camber or toe with our full contact rear shims. For either camber or toe, these nylon shims are available in 9 different thicknesses - giving you the ability to install the exact alignment change needed

71100
71200
71300
71400
SERIES

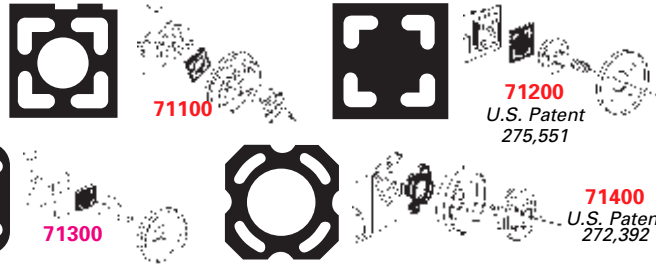

Rear Adjustment range:
Camber $\pm .06^\circ$ to $\pm 1.00^\circ$
Toe $\pm .06^\circ$ to $\pm 1.00^\circ$

Installation time: .5 hr/side

Required: 1 shim per wheel/
per angle changed

APPLICATIONS

See application charts, pages 7-37 for vehicle models and years.

71100 & 71200 SERIES

Audi, Chevrolet, Chrysler, Dodge, Eagle, Ford, Geo, Isuzu, Plymouth, Volkswagen

71300 SERIES

Chrysler, Dodge & Plymouth Mini-Vans

71400 SERIES

Buick, Cadillac, Chevrolet, Oldsmobile, Pontiac

71100	71200	71300	71400	Camber Change	or	Toe Change
71120	71220	71320	71420	.06° (1/16")		.06° [.03" (1/32")]
71121	71221	71321	71421	.13° (1/8")		.13° [.06" (1/16")]
71122	71222	71322	71422	.25° (1/4")		.25° [.13" (1/8")]
71123	71223	71323	71423	.38° (3/8")		.38° [.19" (3/16")]
71124	71224	71324	71424	.50° (1/2")		.50° [.25" (1/4")]
71125	71225	71325	71425	.63° (5/8")		.63° [.31" (5/16")]
71126	71226	71326	71426	.75° (3/4")		.75° [.38" (3/8")]
71127	71227	71327	71427	.88° (7/8")		.88° [.44" (7/16")]
71128	71228	71328	71428	1.00° (1")		1.00° [.50" (1/2")]

72200 HALF SHIM SETS & ASSORTMENT

Adjust camber or toe with these economical options to full contact rear shims. For either camber or toe, sure-grip metal shims are available in four thicknesses.

72300
72400
72800
SERIES

72100 SHIM ASSORTMENT

25 each of 16 items (400 shims total)

This assortment contains 25 each of our popular 72200, 72300, 72400 and 72800 shim series.

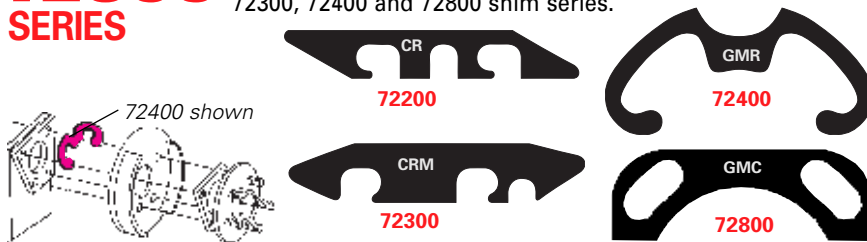

Rear Adjustment range:
Camber $\pm .25^\circ$ to $\pm .75^\circ$
Toe $\pm .25^\circ$ to $\pm .75^\circ$

Installation time: .4 hr/side

Required: 1 shim per wheel

APPLICATIONS

See application charts, pages 7-37 for vehicle models and years.

72200 SERIES

Chrysler, Dodge, Eagle, Plymouth, Volkswagen

72300 SERIES

Chrysler, Dodge & Plymouth Mini-Vans

72400 SERIES

Buick, Cadillac, Chevrolet, Oldsmobile, Pontiac

72800 SERIES Buick, Cadillac, Chevrolet, Oldsmobile, Pontiac

72200	72300	72400	72800	Thickness	Camber Change	Toe Change	Qty
72210	72310	72410	72810	.010"	.25° (1/4")	.25° [.13" (1/8")]	25 ea.
72215	72315	72415	72815	.015"	.38° (3/8")	.38° [.19" (3/16")]	25 ea.
72220	72320	72420	72820	.020"	.50° (1/2")	.50° [.25" (1/4")]	25 ea.
72230	72330	72430	72830	.030"	.75° (3/4")	.75° [.38" (3/8")]	25 ea.

35080 SERIES



NISSAN CAMBER/CASTER SHIMS

These shims install between the upper control arm mount and shaft to adjust Pathfinders and Pickups.

35080 - 1mm 35081 - 2mm 35082 - 3mm

FRONT APPLICATIONS

Nissan 2 & 4WD: 1986 - 97 Pickup, 1987 - 95 Pathfinder

6 Shims per package

REAR APPLICATIONS

Chevrolet: 1963 - 82 Corvette
6 Shims per package

CORVETTE TOE SHIMS

These shims are designed to adjust rear toe on older Corvette models.

47171 - 1/32" 47172 - 1/16" 47173 - 1/8"

47170

SERIES



Camber/Caster Duo-Fit

APPLICATIONS: Buick, Chevrolet, Ford, Lincoln, Mercury, Pontiac, Olds.

Part No.	Thick.	Opening	Qty
37100	1/64"	7/16" to 1/2"	25
37101	1/32"	7/16" to 1/2"	25
37102	1/16"	7/16" to 1/2"	25
37103	1/8"	7/16" to 1/2"	25

APPLICATIONS: AMC, Buick, Cadillac, Chevrolet, Lincoln, Olds, Pontiac, Trucks.

Part No.	Thick.	Opening	Qty
37104	1/64"	9/16" to 5/8"	25
37105	1/32"	9/16" to 5/8"	25
37106	1/16"	9/16" to 5/8"	25
37107	1/8"	9/16" to 5/8"	25

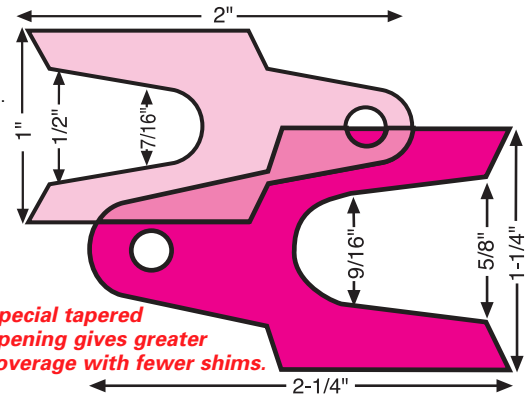

Special tapered opening gives greater coverage with fewer shims.



37150 DUO-FIT ASSORTMENT

Filled with 200 shims - 25 each of all Duo-Fit styles and sizes. Handy organizational chart inside lid makes reordering & organization simple. Comes in a durable plastic case.

INCLUDES 50 EACH:

37105, 37106, 37107, 47151, 47152, 47153, 47181, 47182, 47183, 47766, 47767, 47768, 47775, 47776, 47777

SLA SHIM ASSORTMENT

These camber/caster shims are now available in a corrugated box set to help you organize all of your shims. Covering both cars and trucks this set is perfect for inventory control.



47700

Camber/Caster Shims

47765 - 47769 ("CT")

Part #	Thick.	Qty	APPLICATIONS
47765	1/64"	50	Control arm shaft mounting bolts up to 1/2" diameter.
47766	1/32"	50	
47767	1/16"	50	
47768	1/8"	50	
47769	3/16"	50	

1/2" opening (for most imports)

47775 - 47778 ("CC")

Part #	Thick.	Qty	APPLICATIONS
47775	1/32"	50	Control arm shaft mounting bolts up to 9/16" diameter, including 1/2 ton - 1 ton Chevrolet/GMC trucks, HD service.
47776	1/16"	50	
47777	1/8"	50	
47778	3/16"	25	

9/16" opening (H/D Trucks)

47760 - 47764 ("X")

Part #	Thick.	Qty	APPLICATIONS
47760	1/64"	50	Control arm shaft mounting bolts up to 7/16" diameter.
47761	1/32"	50	
47762	1/16"	50	
47763	1/8"	50	
47764	3/16"	50	

7/16" opening

47150 - 47153 ("US")

Part #	Thick.	Qty	APPLICATIONS
47150	1/64"	50	Control arm shaft mounting bolts up to 5/8" diameter.
47151	1/32"	50	
47152	1/16"	50	
47153	1/8"	50	

5/8" opening

47142 - 47143 ("BS")

Part #	Thick.	Qty	APPLICATIONS
47142	1/16"	25	Universal 1/2" slot shim
47143	1/8"	25	

Universal 1/2" slot shim

47180 - 47184 ("N")

Part #	Thick.	Qty	APPLICATIONS
47180	1/64"	50	Universal 1/2" slot shim
47181	1/32"	50	
47182	1/16"	50	
47183	1/8"	50	
47184	3/16"	50	

Universal 1/2" slot shim



37790 SHIM SET

Shim dispenser 37790 holds a select assortment of shims. The dispenser can be mounted on a bench or hung on a wall.

SET CONTAINS: 47769, 47774 6 EA.) 47775, 47776, 47777, 47778 (8 EA.)
47760, 47763, 47765, 47768, 47770, 47773 (12 EA.)
47761, 47762, 47766, 47767, 47771, 47772 (24 EA.)

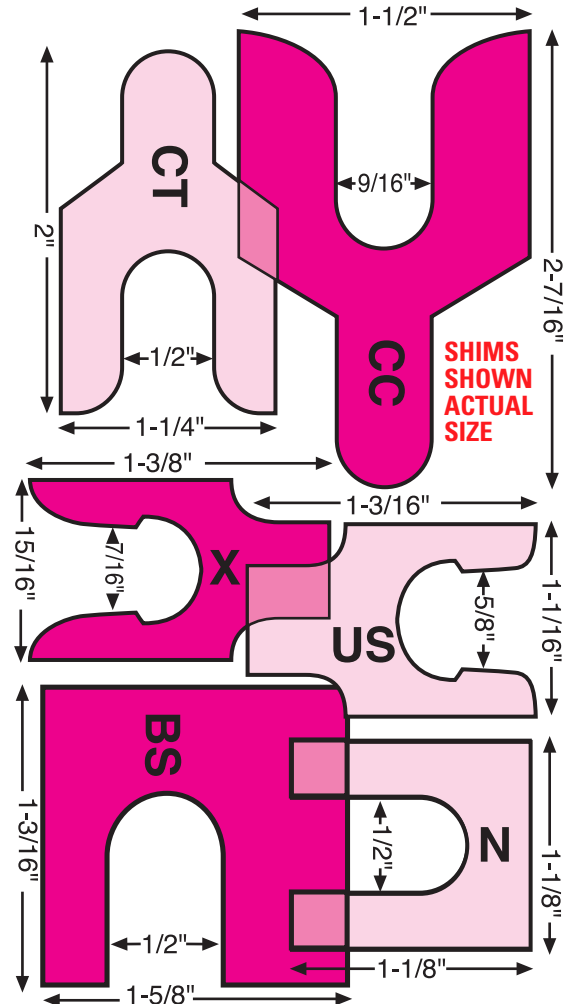

SHIMS SHOWN ACTUAL SIZE

SHIMS
PARTS